



## High-Output BEC Setup and Installation Instructions

Covers Parts #2260

### Kit contents:

- Battery eliminator circuit (BEC)
- Wiring harness with 2-pin male connector
- Heat shrink tubing
- Adhesive foam pad
- Zip tie

### Tools required:

- 2.0mm hex wrench
- Soldering iron (minimum of 40 watts)
- Heat gun
- Side cutters (to trim zip tie)

**IMPORTANT: This BEC accessory is not designed for use on vehicles equipped with dual steering servos.**

### Installation of the wiring harness with 2-pin male connector:

Solder the 2-pin male connector to the High-Current Connector on the electronic speed control (ESC) wiring to provide power to the BEC.

1. Carefully remove the High-Current Connector from the ESC wiring (A).
2. Use a soldering iron to solder the included 2-pin male connector wiring harness to the connector terminals on the ESC wiring. **Important: Note the polarity and wire color.** Solder the red (positive) wire to the terminal with the red wire and the black (negative) wire to the terminal with the black wire (B). **Note:** The wires are pre-stripped and tinned.
3. Pull the red and black wires apart (C).
4. Slide the included heat shrink tubing over the red (positive) and black (negative) wires (D). Use a heat gun to shrink the tubing and secure the wires in place (E). **Note:** The heat shrink tubing is provided for strain relief and is not to cover the soldered connections. Shrink the tubing onto the wires as shown, leaving the soldered connections exposed.
5. Reinstall the High-Current Connector (F). **Important: When inserting the terminals with the wires soldered on, note the polarity and wire color.** Insert the red (positive) terminal into the "+" side and the black (negative) terminal into the "-" side.

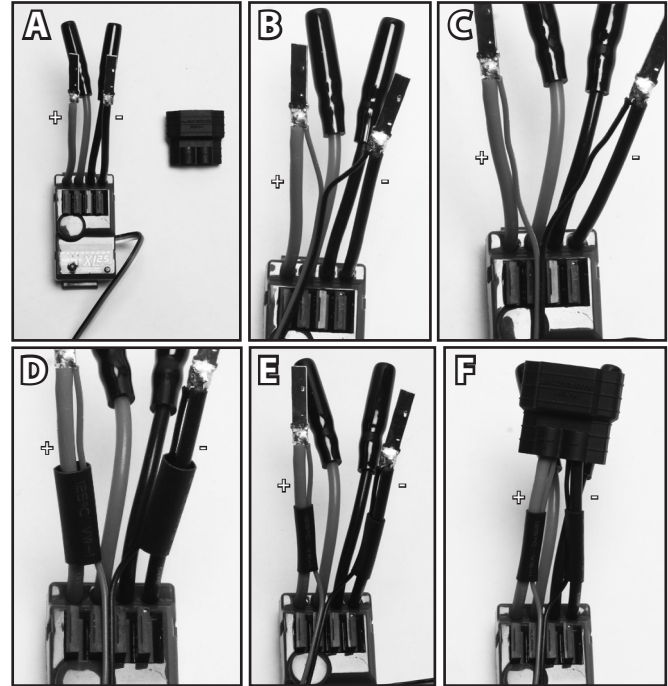

*Note: The ESC (electronic speed control) shown for illustrative purposes only. Your ESC may differ from the one shown, but the soldering process for installation of the 2-pin wiring harness will be the same.*

### BEC Installation:

1. Remove the screws from the receiver box cover; remove the cover.
2. Peel the backing from the adhesive foam pad and secure it the bottom portion of the BEC.
3. Remove the backing from the other side of the adhesive foam pad and install the BEC onto the vehicle chassis. **Note:** Choose a location on the chassis where the power wire from the BEC will reach the red 2-pin male connector installed on the ESC wiring, and the receiver wires from the BEC will reach the inside of the receiver box.
4. Plug the red female connector from the BEC power wire into the red 2-pin male connector installed on the ESC wiring.
5. Unplug the ESC connector from Channel 2 of the receiver. Route the wire outside of the receiver box and plug the connector into the BEC. **WARNING:** The BEC is waterproof, but the connections to the radio system are not protected and are subject to interference when running your model in wet conditions. To avoid this potential radio interference, apply a small amount of silicone grease (part #1647, sold separately) to the ESC connector when needed. For TRX-4 models, use of the complete BEC kit, part #2262, is recommended.
6. Route the black connector from the BEC into the receiver box and plug the connector into Channel 2 of the receiver.
7. Reinstall the receiver box cover. *Refer to your vehicle Owner's Manual for detailed instructions on maintaining a watertight seal.*
8. Use the included zip tie to coil and secure any excess length of the BEC wiring to prevent contact with any moving parts or assemblies.

### Wiring Diagram

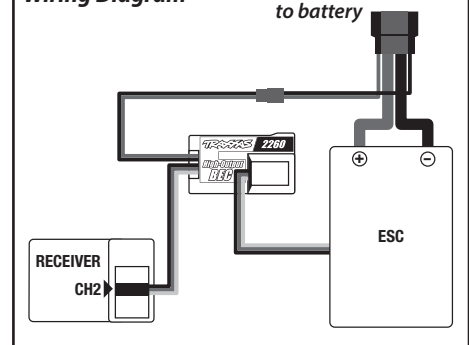

This device complies with FCC Part-15 & IC RSS-210 rules subject to the following conditions: 1) This device may not cause harmful interference, and 2) This device must accept all interference received, including interference that may cause undesired operation.